

DRUM TILTERS

Bushman AvonTec manufactures drum handling equipment that holds drums securely during pick up, movement, and discharge operations. Each ergonomically designed tilter permits precise rotation, from the vertical to the horizontal plane and beyond, for controlled pouring and dumping.

All Bushman AvonTec's drum tilters meet or exceed the requirements of the latest revisions of ASME Specifications B30.20 and BTH-1, Design of Below the Hook Lifting Devices.

The self-locking worm drive speed reducer holds the drum in position without roll-back during the tipping operation. In addition to the standard features described below, most Bushman AvonTec drum tilters can be modified for a variety of different drum sizes and types including those frequently used for hazardous materials.



MODEL 770 ROTATING DRUM TILTER

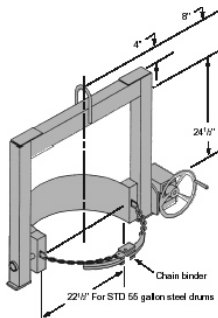

Model 770 rotating drum tilters enable the operator to pick up and move drums and dispense their contents accurately.

This model includes a quick release chain load binder that simplifies drum engagement and disengagement. The ergonomically designed rotation mechanism includes a self-locking gear reducer actuated by a hand wheel. An optional chain wheel permits rotation of the drum when the unit is beyond the operator's reach.

The standard model 770 works with 55 gallon drums. These units can be modified to handle a variety of drum styles and sizes except for fiber or plastic drums.

MODEL 775 ROTATING DRUM TILTER

The model 775 rotating drum tilter employs a cradle assembly to support the weight of the drum. Two chain binder assemblies hold the drum in the basket during rotation. This design permits the unit to hold the drum securely and ensures precise positioning without relying on a pressurized clamping or engagement mechanism.

Model 775 tilters accommodate a variety of drum sizes and styles, including plastic and fiber drums. Model 775 tilters are particularly useful when handling drums that are damaged or that cannot withstand high compression engagement. Choose this model whenever the outside surface of the drum will not permit proper engagement by clamping alone.



MODEL M775 ROTATING DRUM TILTER

Motorized rotation is available with the Model M775 drum tilter. This feature provides greater handling ease and more precise positioning for pouring and dumping. It is also an important safety feature since it frees the operator from the necessity from working in the immediate vicinity of the dumping operation.

Standard units are available with the following voltages: 230-460/3/60 and 110/1/60. Air operated versions and special voltages/frequencies are available.



MODEL 771 ROTATING DRUM TILTER

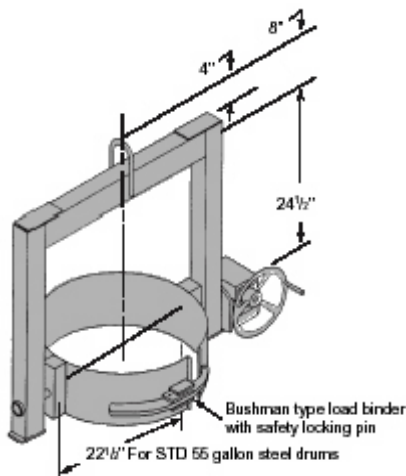

The Model 771 is a heavy duty drum tilter designed to manipulate drums in high production areas.

While similar to Model 770, this unit includes a solid steel band and lock mechanism in place of the chain load binder. This steel band maintains the integrity of the drum by increasing surface contact between the drum and the lifter. It also holds the drum more securely and provides greater control during pouring.

This model is equipped with an ergonomically designed rotation mechanism actuated by a hand wheel with a self-locking gear reducer. A chain wheel option is available to permit rotation of the drum when the unit is beyond the operator's reach.

The standard model 771 is designed for 55 gallon drums, but it can also work with a variety of different drum styles and sizes.

MODEL M771 ROTATING DRUM TILTER

Motorized rotation is available with the Model M771 drum tilter. This feature provides greater handling ease and more precise positioning for pouring and dumping. It is also an important safety feature since it frees the operator from the necessity of working in the immediate vicinity of the dumping operation.

Standard units are available with the following voltages: 230-460/3/60 and 110/1/60. Air operated versions and special voltages/frequencies are available.



USA

P.O. Box 309
Butler, WI 53007-0309

W133 N4960 Campbell Drive
Menomonee Falls, WI 53051

Phone: (800) 338-7810
(262) 790-4200
Fax: (262) 790-4202

CANADA

1680 Brampton Street
Hamilton, ON
Canada L8H 3S1

Phone: (800) 844-8117
(905) 689-7994
Fax: (905) 689-8472